

A Thermal Modeling Comparison of Typical Curtainwall Glazing Systems

Lawrence D. Carbarry, Associate Industry Scientist ¹ & Fiby Albert, Application Engineer/Technical Service ²

¹ Dow Corning Corporation, PO Box 994, Midland MI 48686-0994, USA

² Dow Corning Seneffe, Parc Industriel Zone C, B-7180 Seneffe, Belgium

Keywords

1= Structural Glazing

2= Thermal Modeling

3= Gaskets, Curtainwall

Abstract

This paper compares the U value and energy consumption of typical curtainwall glazing systems used in commercial buildings. These glazing practices are popular in the major cities of the world. There are four basic types of systems that are compared. 1) Glazing systems that use Insulating glass which are mechanically fixed in gaskets, 2) 4 sided structural silicone glazed with wet weatherseals, 3) 4 sided structural silicone glazed with dry gasket weatherseal, and 4) Hybrid glazing system (structurally clamped).

The thermal modeling is performed based upon WinISO 2D using three different IG unit designs for the first three systems noted above. The IG unit designs evaluated are: 1) aluminium spacer 2) stainless steel spacer, and 3) warm edge spacer technology. The hybrid glazing system is modeled only with an aluminum spacer.

After calculating the U Value for a system, the results can be used to demonstrate how to evaluate the energy consumption for a specific system in a specific location, and compare these results relative to different configurations.

This paper details that mechanically fixed systems demonstrate good initial performance, but the aging of gaskets results in shrinkage. Furthermore, compression set of the gaskets allows additional air and water infiltration, rendering the system even less effective. Gasket joint systems also allow additional exposure to the elements of the middle of the aluminum system which further decreases the energy efficiency. Structural glazed systems using the warm edge technology provides an excellent U value and results in the most energy efficient system modeled.

Introduction

The US Department of Energy, Office of Energy Efficiency and Renewable Design publishes an approach to Whole Building Design. This design approach considers all building components during the design phase by integrating subsystems and parts of the building into a working model. There is a need for specialists in materials, construction

professionals, and owner/occupant advocates to come together at the beginning of a project to understand the advantages of the Whole Building Design approach.

"Commercial buildings consume 17% of the total energy consumed in the United States. By creating buildings that use less energy and have lower power demands, greater robustness of the buildings as well as the power grid is achieved. This reduces the need for fossil fuels and consequential environmental impact." [1]

This is a startling statistic, 17% of the total energy consumed in the US is consumed by commercial buildings. In 2005, energy use per person in the US was 337 million British Thermal Units (BTU) for a total US energy use of 100,800 Trillion BTU. [2] The commercial sector consumed 18093 Trillion BTU's during this time frame.

The same statistics are reflected in the European Community through the European Commission Website. "The buildings sector accounts for 40% of the EU's energy requirements. It offers the largest single potential for energy efficiency". [3] A large amount of energy consumed is consumed by the commercial sector.

The architectural appeal of major commercial buildings around the world is seen in the new construction projects that appear in the city skylines of the world's large cities. The glass and metal structures that are designed by the

top architectural firms in the world are works of art and functionality. They are designed for human comfort in the workplace to help the workers be efficient in their environment. The building owner must offer this comfortable environment to attract quality tenants and/or employees. Tenants and employees pay the rent, energy cost and maintenance. In the present times we are embracing that improving energy efficiency in all aspects of our lives is important because it can reduce greenhouse gas emissions and reduce the need for excess energy. The publicity surrounding the Kyoto protocol has helped make people aware of this important issue.

Commercial buildings require glass and structural glazing to be attractive, from the interior and exterior. Vision assemblies are more efficient today than anytime in the past.

Noted in Figure 1 below is the U value of various types of glazing assemblies. As most commercial buildings have evolved, a significant step change was made in the U value performance and therefore reduced energy consumption with the addition of a second piece of glass as a sealed Insulating glass unit. Additions of inert gasses (such as argon), the development of low emmissivity coatings (Low-E), and the addition of a third pane continue to improve the efficiency of a commercial façade. The graph below shows center-pane thermal transmittance values (Ug)

Figure 1
U value of various types of glazing assemblies

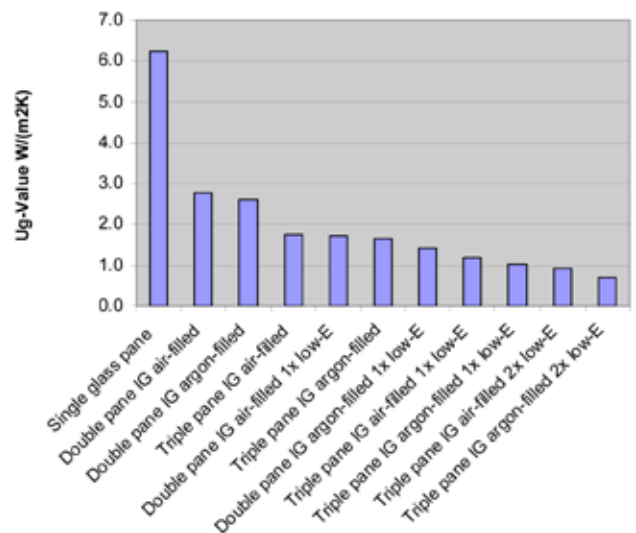

for different IG configurations (assuming a 12 mm glazing gap between the glass panes and an emissivity of 5% for the low-emissivity coatings) [4]

As can be seen, triple-glazed IG units filled with argon gas and combining two panes of glass with low-E coatings are capable of achieving a U_g value of $0.7 \text{ W/(m}^2\text{K)}$.

This value can be further improved by the use of other fill gases, such as krypton or xenon, which allows the achievement of U_g values of approximately 0.6 and $0.5 \text{ W/(m}^2\text{K)}$. However, these additional steps add cost to the façade and the payback to the owner is always considered. As noted above, this graph shows the center-pane thermal transmittance values.

Typical wall (non-glass) U_g values are in the range of $0.3\text{--}0.6 \text{ W/(m}^2\text{K)}$. Additionally, roofs are in the range of $0.15\text{--}0.3 \text{ W/(m}^2\text{K)}$. These two components often comprise most of the surface area of the typical building, hence the focus continues on the relative inefficiency of the glazing systems.

The technology of increasing the efficiency of glazing systems is becoming more important everyday because of the vast amount of surface area that glazing represents. However, typically the framing systems and attachment methods have not been studied in the same manner. But, the framing and attachment methods require the same attention to detail. Typical frames are made of aluminum, one of the best thermally conductive metals known. Many techniques such as gaskets, silicone gaskets, wet sealants, polyurethane thermal breaks and polyamide thermal breaks exist to thermally break the aluminum frames and isolate interior and exterior environments. In this study, we are exploring four common methods of glazing attachment.

Objective

This paper documents the study of the perimeter of the glazing assembly. The method of attachment of the glazing has an impact on the overall thermal transmittance of the system.

For sake of simplicity, a single aluminum framing system is explored. The basic frame is 75mm wide and 125 mm deep with a 3mm wall thickness and shown in Figure 2. As noted, there is some slight alteration in this frame due to the types of attachment methods used.

Comparisons are made between four types of glazing systems that attach the glass to the frame to discuss this aspect. The four types of systems include

1. Standard method of mechanically capturing the insulating glass system in EPDM gaskets where the exterior mechanical restraint is thermally isolated from the interior frame
 - a) This system is modeled for both a new installation and aged installation.

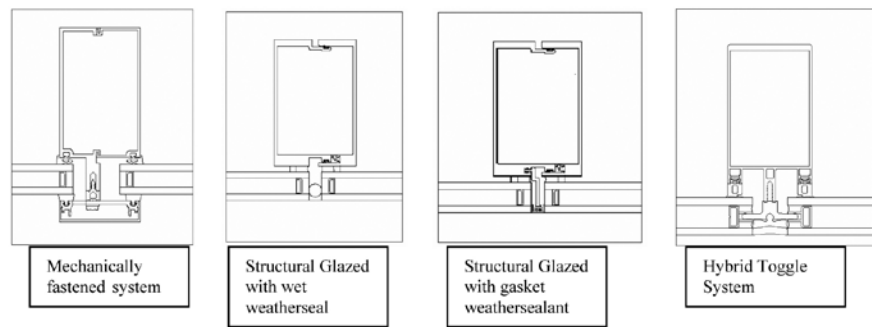

Figure 2
Types of frame and fastening systems.

- The aged installation is assumed to allow additional exterior air exposure due to gasket shrinkage.
2. Structural Glazing of insulating glass using structural silicone and having a closed jointing system on the exterior that incorporates wet applied weathersealant.
3. Structural Glazing of insulating glass using structural silicone and having a dry gasket joint system.
4. A hybrid system where the insulating glass unit has a channel about the perimeter to mechanically anchor the system to the frame with a polyamide toggle and an aluminum IG spacer. All glass considered in this study is insulating glass and has the same dimension and coating and is the same configuration in each simulation. The insulating glass makeup is 6mm glass, 15mm airspace, 6mm glass. The coating on the glass is chosen to be a Low e coating of 4 % emissivity on the #3 surface. The U value of the glass is $1.393 \text{ W/m}^2\text{K}$.

Three different glass spacer designs are studied. Each design is a dual sealed Insulating glass unit using Polyisobutylene (PIB) as the primary seal and a silicone insulating glass sealant as the secondary sealant. Silicone as the secondary sealant was chosen due to the durability.

Cardinal Corporation notes that Silicone PIB dual sealed IG units demonstrate a 0.5% failure rate compared to Polysulfide PIB dual sealed units which demonstrate an 8% failure rate over 20 years [5]. Silicone was also chosen for this study because it is the only sealant technology acceptable for use as a structural adhesive for structural glazing applications in commercial facades. The dimension of the silicone secondary seal in these units was held constant at 6mm x 15mm. The first IG spacer is made of aluminum, the second made of stainless steel, and the third is a warm edge spacer made of foamed desiccated silicone.

Results and Discussion

The frames that are used are intended to make a comparison of the glazing system. The frames are relatively poor in thermal performance, but the exercise here is not to optimize the frames, but rather have a good relative comparison between glazing options. It should

also be further emphasized that the insulating glass units are the same. This was not to optimize the choice of glass, but to reflect only on the IG spacer design and glazing system.

The temperatures chosen are in alignment with European Standards. The data can be recalculated easily using the ASHRAE standards commonly used in the US.

The first frame designs modeled are insulating glass units mechanically captured in EPDM gaskets.

The second set of frames modeled are the same insulating glass units mechanically captured in gaskets, however the exterior gasket was not in direct contact with the glazing. This simulates a long term aging condition where the weather has reduced the flexibility of the gaskets and they are loose in the opening. Where this happens, typically in the areas of the globe with hot summers, the buildings are then wet sealed from the exterior to minimize the infiltration of air and water. This restoration event is done at a cost to the owner to increase tenant satisfaction and reduce energy costs.

The third set of frames modeled were insulating glass units that are structurally attached to a frame and weather sealed with a wet sealant. The design is a vertical design for a unitized curtainwall, hence the split mullions are used.

The fourth set of frames modeled were insulating glass units structurally attached with silicone to a frame with a dry gasket is inserted between the units instead of a wet sealant.

The final frame modeled was a hybrid toggle system where a specially designed insulating glass unit is mechanically fastened to the frame with a toggle. The software here assumes that the toggle attaching the IG unit is made of polyamide and omitted due to the fact that the toggle is discontinuous. When modeling with a continuous toggle, the U values and temperatures we not significantly different. Properly modeling this requires 3 dimensional software. We note both conditions in the table below and show that they are essentially equivalent.

Winlso 2D software was used to thermally model the various designs. The study uses interior temperatures of 20°C and an exterior temperature of -5°C . Thermal gradients are shown in

Type of glazing system	U value Frame W/m ² °K	IG spacer design	Interior profile temp °C	Interior glass temp °C	U value* façade W/m ² °K	Overall Rating **
Mechanically fixed new	3.652	Aluminum	15.91	11.19	2.05	12
	3.652	Stainless Steel	15.83	11.74	2.02	8***
	3.652	Warm Edge Silicone Foam	16.35	13.55	1.88	4
Mechanically fixed aged	3.711	Aluminum	13.45	11.60	3.39	14
	3.711	Stainless Steel	13.56	11.86	2.37	13
	3.711	Warm Edge Silicone Foam	14.05	13.19	2.35	9***
Structural Silicone with wet weatherseals	1.126	Aluminum	17.19	13.09	1.90	6
	1.126	Stainless Steel	17.32	13.27	1.87	3
	1.126	Warm Edge Silicone Foam	18.17	14.68	1.66	1
Structural Silicone with gasket weatherseal	1.639	Aluminum	16.88	13.09	1.96	7
	1.639	Stainless Steel	17.00	13.29	1.93	5
	1.639	Warm Edge Silicone Foam	17.94	14.67	1.70	2
Hybrid Toggle system continuous polyamide toggle	2.371	Aluminum	16.2	8.12	1.99	10***
Hybrid Toggle system, toggle omitted	2.371	Aluminum	16.2	8.35	2.02	11***

* Calculation done based on EN10077 -2 using a 1m x 2m glazing panel with the U value of 1.393 W/m²°K and a low e coating of 4 % emissivity on the #3 surface

**The overall rating is determined by ranking each property, profile temp, glass temp, and façade U value, in order from 1-14. These three rankings are then averaged and the average ranking is assigned. For instance the structural silicone glazed system with wet weatherseals had a #1 ranking on profile temp, #1 ranking on glass temperature, and a # 1 ranking on the façade U value. This resulted in an average of 1 [(1+1+1)/3] for the top ranking.

*** The average rankings of systems 8-11 were all essentially equivalent using this ranking system.

Table 1

Data provided from the study

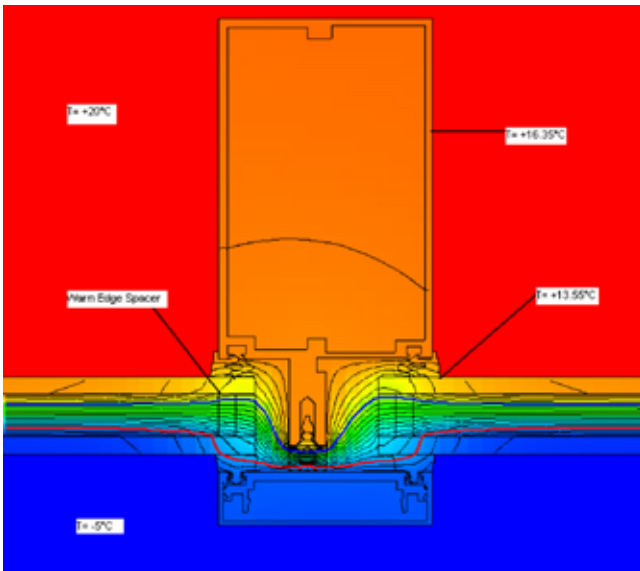

Figure 3.1
Mechanically fixed with warm edge IG, new installation

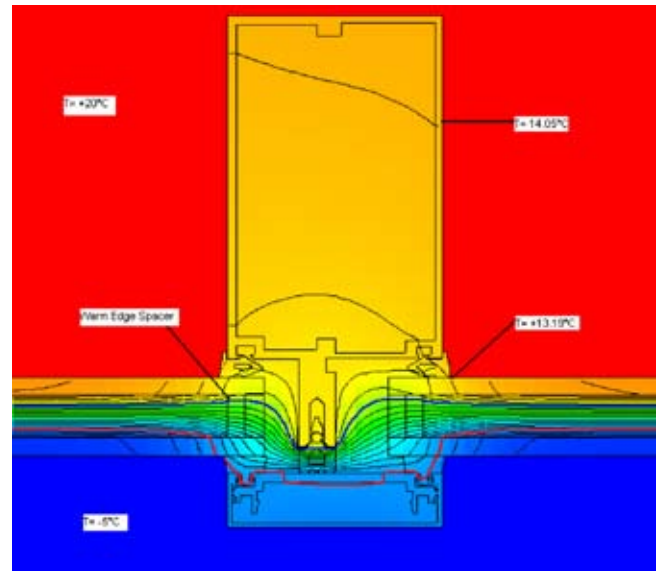

Figure 3.2
Mechanically fixed with warm edge IG, aged installation

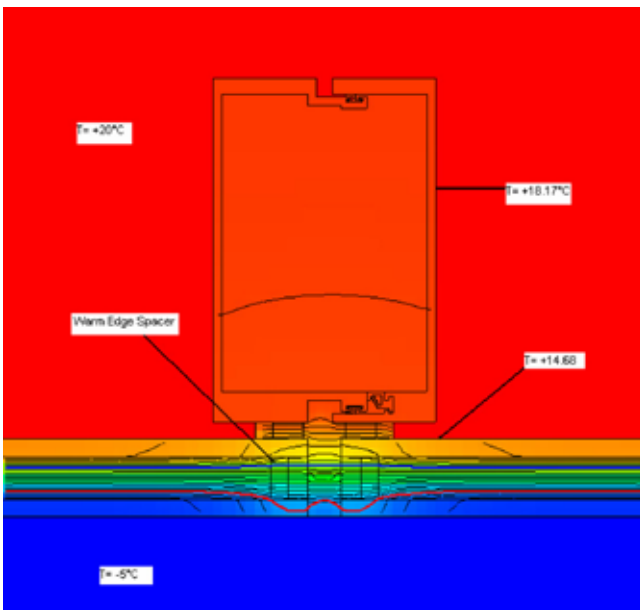

Figure 3.3
Structurally glazed with warm edge IG and wet weatherseal

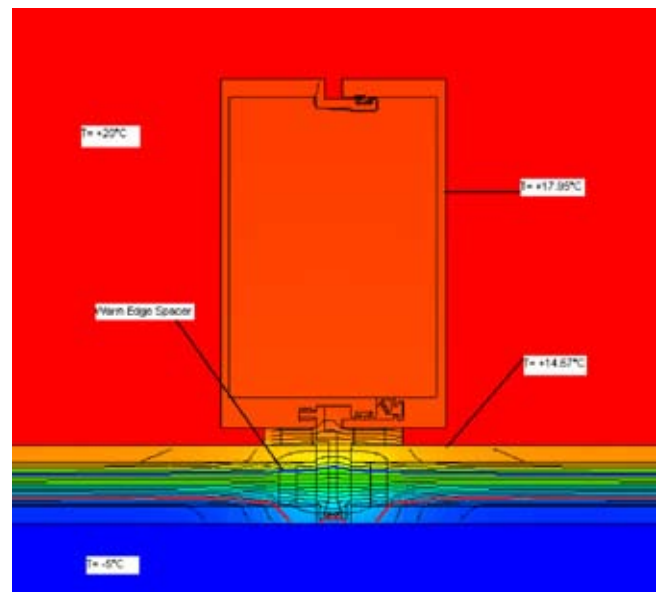

Figure 3.4
Structurally glazed with warm edge IG and dry gasket weatherseal

figures 3 of each frame modeled.

For the sake of saving space, the thermal inclines are not produced for each IG design. The data is tabulated in table 1.

The relative rankings were assigned by averaging the ranking the overall façade U value, interior profile temperature, and the interior glass temperature.

When studying the table it is noted that the biggest positive impact on the system is the use of the warm edge IG in conjunction with structural silicone glazing. Within the top seven ranked systems, six of them were the silicone structurally glazed models. All silicone glazing designs used a 6mm x 12mm structural bead and a 6mm x 6m silicone spacer. Ranking #4 is a mechanically fastened system using a warm edge spacer.

Also noted here is the lower performance of a system that has gaskets that are not in intimate contact with the glazing system. This was done to simulate experiences in the field with aged organic gaskets. When buildings leak air and water, the energy costs rise due to the inefficiencies in the glazing system.

Rankings 8-11 were all essentially equivalent in this ranking system.

It is well known that the durability of silicone materials allow them to be used for structural glazing applications. The first structural glazing project using 4 sided structural silicone glazing was completed in 1971 [6], and is still performing today in Detroit Michigan, USA. This testimonial to durability is regularly highlighted in the construction industry. Silicone Structurally Glazed (SSG) systems are now accepted through out the world because of this proven durability. Silicone materials are also able to be extruded into gaskets and demonstrate the same durability and performance as the wet applied sealants with regards to UV resistance, non-shrink characteristics, low compression set, and weatherability. It is suggested that mechanically fastened systems will maintain there performance longer with regards to weather tightness and thermal efficiency when they employ gasket materials made of silicone.

Energy Usage

The flow of energy can be calculated as the façade U value, multiplied by the area, multiplied by the temperature difference between the interior and exterior. When comparing one system to another, it is suggested that the façade U value of the fenestration area be studied. The best façade U value modeled here is 1.66 W/m²°K and the worst was 3.39 W/m²°K.

A good exercise to understand the impact of the U value is to perform a simple calculation at the peak heating or cooling temperatures when the indoor temperature is controlled.

Figure 3.5
Hybrid toggle system

Figures 3.1-3.5
Thermal inclines of each design with a warm edge spacer.

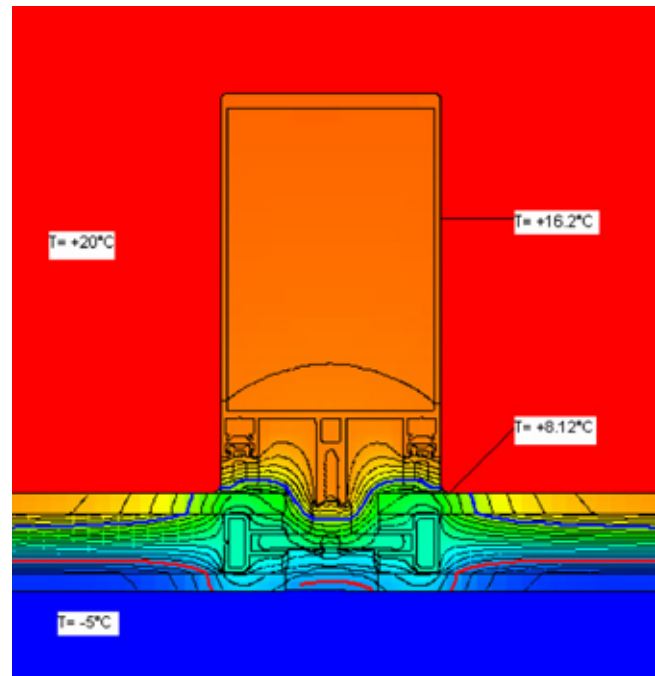

Table 2
Energy usage example of modeled façade systems at a 20°C and 40°C differential

Ranking	U façade values	Watts/m ² required at 20°C differential	Watts required at 20°C differential for 1000 m ² façade	Watts/m ² required at 40°C differential	Watts required at 40°C differential for 1000 m ² façade
1	1.66	33.2	33200	66.4	66400
2	1.7	34	34000	68	68000
3	1.87	37.4	37400	74.8	74800
4	1.88	37.6	37600	75.2	75200
5	1.9	38	38000	76	76000
6	1.93	38.6	38600	77.2	77200
7	1.96	39.2	39200	78.4	78400
8	1.99	39.8	39800	79.6	79600
9	2.02	40.4	40400	80.8	80800
10	2.02	40.4	40400	80.8	80800
11	2.05	41	41000	82	82000
12	2.35	47	47000	94	94000
13	2.37	47.4	47400	94.8	94800
14	3.39	67.8	67800	135.6	135600

The thermal inclines noted above are for -5°C outdoors and 20°C indoors. Although this is according to European Standards, there are significant portions of the globe that reach nighttime temperatures of -20°C whilst maintaining the 20°C interior temperature.

The table 2 provides the insight that the lower U façade values are desirable. Energy use is a direct cost to the building owner who must recover the cost from the occupants. The cost of energy is different in all parts of the globe and the value of upgrading systems or restoring systems will vary based on these energy cost.

Rankings #12 and #14 are interesting to review in the above table. These two rankings are the difference between an aged gasket glazed model and a new one. The aged system is predicted to require 44% more energy at peak heating to maintain the interior temperature. This type of scenario is the motivation of the building owner to entertain a façade restoration project.

Conclusions

Silicone Structural glazed Warm Edge IG units showed the best thermal efficiency in this study. Additionally, warm edge insulating glass consistently showed better thermal efficiency. Where gaskets were modeled to have lost their resiliency, the mechanically fixed systems show increased U value and therefore higher energy usage at peak loads.

The silicone systems outperform the hybrid and mechanically fixed systems based on interior profile temperatures, interior glass temperatures and façade U value. Warm edge technology spacer offers significant advantages to a glazing system.

Future Work

Energy usage modeling will become easier with user interfaces that are user friendly. Energy modeling today is used in proprietary systems and concentrates on HVAC equipment. However, studies like this will be more common to the

building industry in the future. The thermal model noted above will be the basis of others fine tuning proprietary design to make trade offs based on the aesthetic need of a project, ease of erection, and availability.

Bibliography

1. US Department of Energy, Office of Energy and Renewable Design website http://www.eere.energy.gov/buildings/highperformance/design_approach.html August 10, 2006
2. Energy Information Administration, Monthly Energy Review Feb 2007, page 25 <http://www.eia.doe.gov/emeu/mer/contents.html>
3. European Commission http://ec.europa.eu/energy/demand/legislation/buildings_en.htm February 19, 2007
4. GANA – Glass Association of North America – Specifiers Guide to Architectural Glass – 2005 Edition
5. Cardinal Corporation http://www.cardinalcorp.com/products_xledge/xledge.htm
6. Hilliard, J. R., Parise, C. J., and Peterson, C. O. Jr., Structural Sealant Glazing, Sealant Technology in Glazing Systems, ASTM STP 638, ASTM International, West Conshohocken, PA, 1977, pp. 67-99